

# Truflo TF100 Post Hydrant

Specify Kupferle's *Premium* Truflo TF100 3/4" & 1" Washdown Hydrant for Potable Water Applications



Truflo #TF100

- Basic Hydrant Style – No Casing Guard
- All Brass/Bronze and Steel Construction
- Optional Riser Pipe and Operating Rod Materials of Construction i.e. Steel as shown, Galvanized Steel, #316 Stainless Steel or brass.
- No-lead brass available
- Outlet Sizes 3/4 GHT or 1" MNPT
- Aluminum, Stainless Steel or Brass Cam & Groove Quick Disconnect Adapters available
- Inlet sizes 3/4" or 1" MNPT Bronze Vertical Inlet.
- Maintainable from Above Ground, no digging
- Optional Backflow Prevention including Outlet Vacuum Breaker and/or Double Ball Check Valve on Drain
- Four Spoke Ball Wheel Operating Handle
- Optional Deck Mount Flange
- Unique Valve Delivers Full-Flow

TRUFLO™



The Kupferle Foundry Company  
2511 North 9<sup>th</sup> Street  
St. Louis, MO 63102  
800-231-3990 / [www.hydrants.com](http://www.hydrants.com)  
Contact us at [info@hydrants.com](mailto:info@hydrants.com)



# TF100 TRUFLO POST HYDRANT NO CASING GUARD

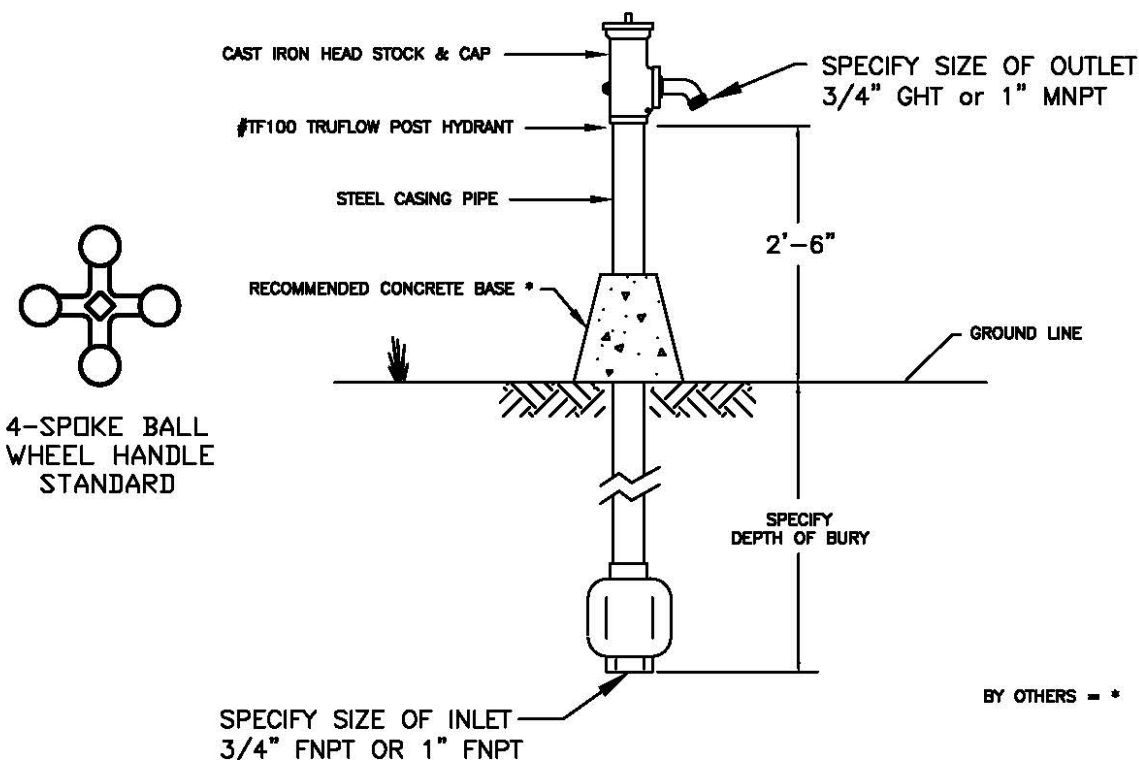

BY OTHERS - \*

Hydrant shall be \_\_\_\_ ' Depth of Bury with a 3/4" or 1" FNPT vertical inlet and a 3/4" GHT or 1" MNPT outlet.

Hydrant shall be non-freezing, self draining. Hydrant shall have a cast iron head and cap, a (steel (STD), galvanized steel, stainless steel or brass) exterior casing pipe, a (steel (STD), galvanized steel, stainless steel or brass) non-turning interior operating rod and bronze valve body. Hydrant shall be operated by 9/16" square operating nut with a 4-spoke ball wheel operating handle.

Hydrant must seal the drain outlet in all positions from 1/4 closed to fully open. All internal; working part shall be removable from above ground with no digging required.

Hydrant shall be set in 4 cubic feet of crushed stone to allow for proper drainage of the hydrant, Recommendations of the AWWA should be followed for installation of the hydrants.

Hydrant shall be Model TF100 TruFlow Post Hydrant as manufactured by the Kuperle Foundry Company, St. Louis, MO 63102 or approved equal.

		THIS DRAWING IS THE PROPERTY OF THE KUPFERLE FOUNDRY COMPANY. IT IS NOT TO BE USED OR DUPLICATED WITHOUT PERMISSION OF THE OWNER.	DRAWN	 <b>KUPFERLE FOUNDRY COMPANY</b> 2511 NORTH 9TH STREET, ST. LOUIS, MO 63102 314-231-8738 800-231-3990 FAX 314-231-2820 <a href="http://www.hydrants.com">http://www.hydrants.com</a>	
			APPROVED		
			DATE		
			MAT'L		
DATE	REVISION	PART NO. #2 ECLIPSE POST HYDRANT	SHEET	OF	

# #TF-100 CUT SHEET

(#TF-100-B STANDARD SHOWN)

## PARTS LIST

ITEM	QTY	PART NUMBER	DESCRIPTION	NOTES
1	5.16	1 1/4P	1-1/4" STEEL PIPE (BARREL PIPE)	B,C
2	5.29	1/2P	1/2" STEEL PIPE (OPERATING ROD)	B,C
3	1	10101	BRASS INLET VALVE	C
4	1	10102	IRON TOP CAP (TF100)	C
5	1	10103	IRON HEADSTOCK (TF100)	C
6	1	10105	PLUNGER	
7	1	10106	PLUNGER BOLT	
8	1	10122	TOP CAP GASKET	C
9	1	10143	TF100 BRASS WASHER	C
10	1	10220	O-RING FOR TRUFLO SCREW	C
11	1	10241	BRASS CONNECTING NUT	C
12	2	10248	TOP CAP BOLT	
13	1	1699	IRON HANDLE	C
14	3	2019	O-RING FOR PLUNGER	C
15	1	321	1" BRASS NOZZLE	C
16	1	329	SEAT RUBBER	
17	1	500TF	BRASS OPERATING SCREW (1699 HANDLE)	
18	1	77C	HANDLE BOLT	
19	2	77Q-88	TOP CAP NUT	C
20	1	77W	HANDLE WASHER	
21	1	9419	PLUNGER WASHER	

## OPTIONAL PARTS LIST

22	0	1 1/4GAL	1-1/4" GALVANIZED PIPE (BARREL PIPE-5.16FT)	A,B,C
25	0	1/2BP	1/2" BRASS PIPE (OPERATING ROD-5.29 FT)	A,B,C
23	0	1 X 3/4BA	1" x 3/4" GHT BRASS ADAPTER	A
24	0	1 X 3/4BHB	1" x 3/4" BRASS HEX BUSHING	A
26	0	10102-B	BRASS TOP CAP (TF100)	C
27	0	10103-B	BRASS HEADSTOCK (TF100)	C
28	0	10157	ALUMINUM GUARDS	C
29	0	10258	ALLEN SET SCREW	C
30	0	10259	ALLEN SCREW	C
31	0	182	3/4" IRON CASING GUARD	C
32	0	345-N-500	CASING GUARD NUT	C
33	0	345-S	CASING GUARD SCREW	C

## REPAIR KITS

PART NUMBER	DESCRIPTION	PARTS INCLUDED
X10105	TF100 PLUNGER COMPLETE	10105 PLUNGER (1), 2019 O-RING (3), 329 SEAT (1), 9419 WASHER (1), 10106 BOLT (1)
X500TF	BRASS TOP SCREW FOR HANDLE COMPLETE	500TF BRASS TOP SCREW (1), 10220 O-RING (2)
XTF100RK	TF100 REPAIR KIT	10105 PLUNGER (1), 2019 O-RING (3), 329 SEAT (1), 9419 WASHER (1)

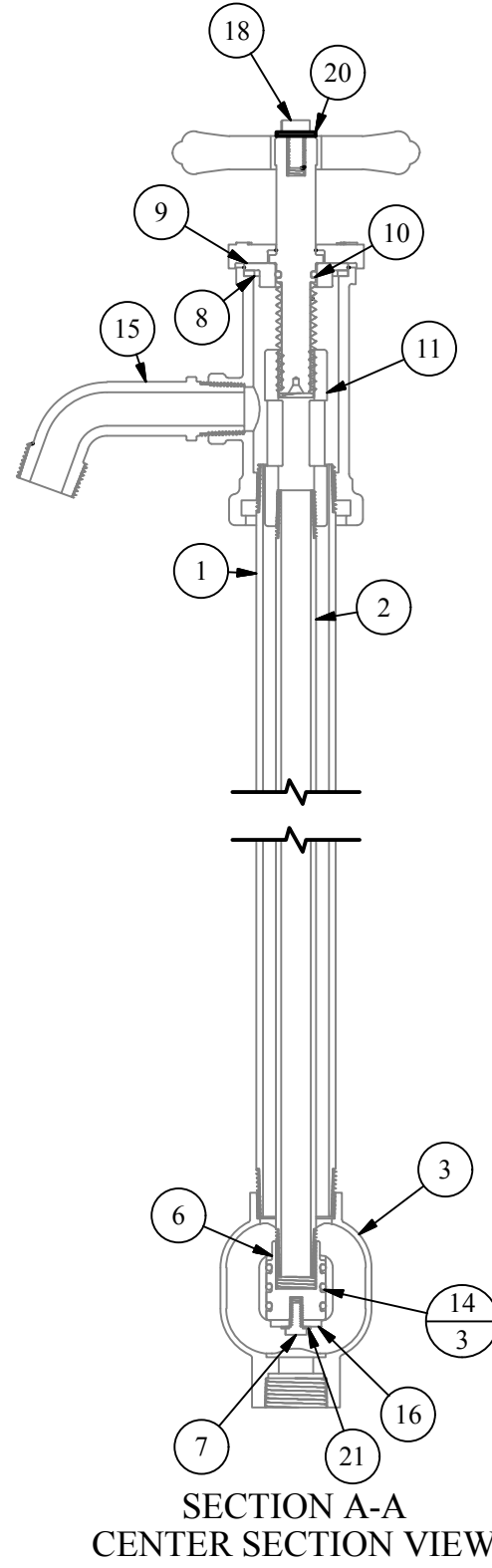
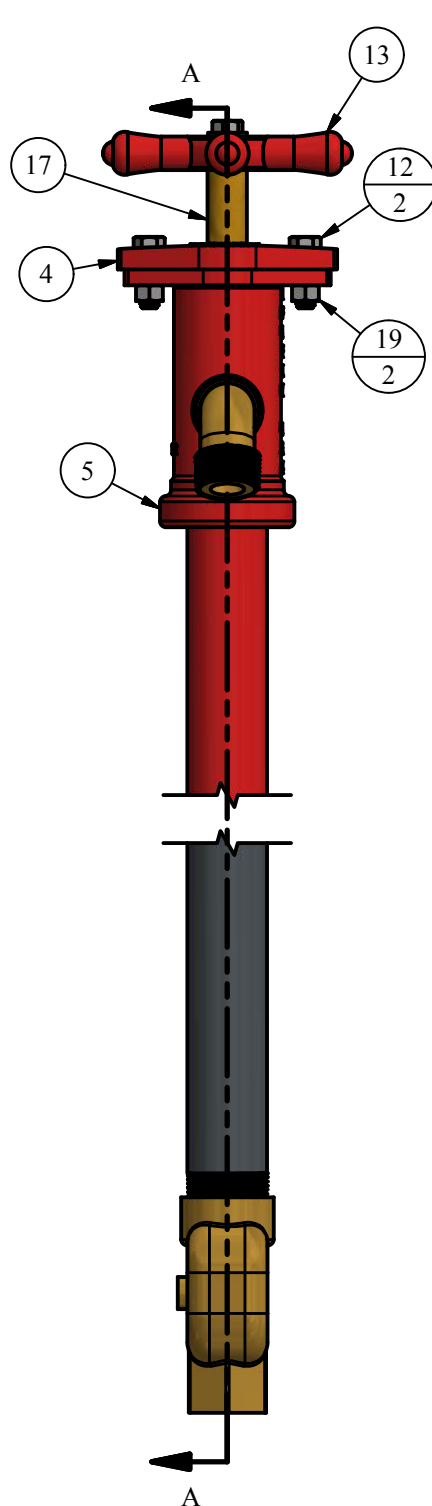

## TOP STOCK ASSEMBLY

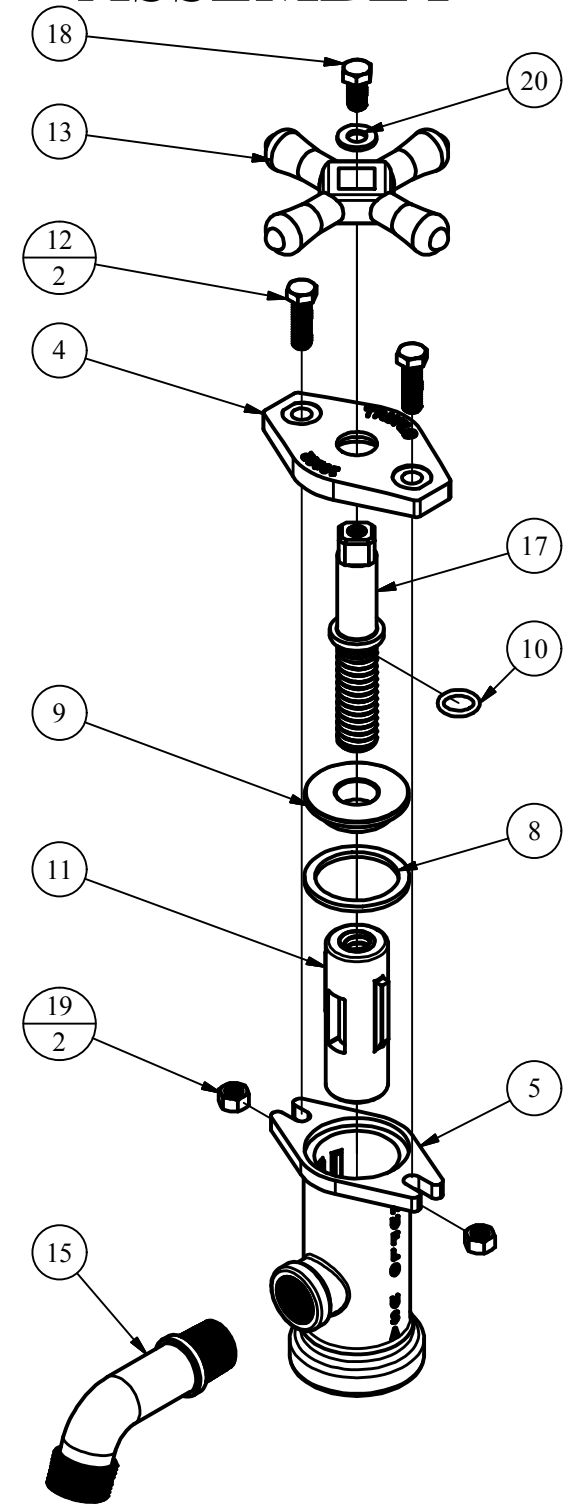

## PLUNGER ASSEMBLY

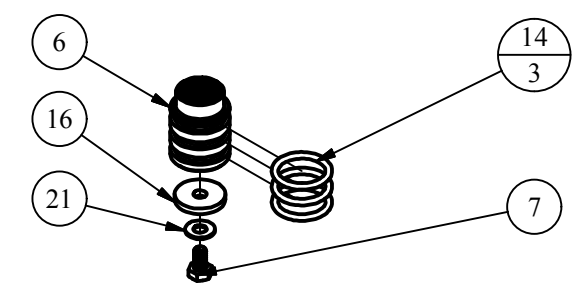

## #TF-100-O YARD HYDRANT

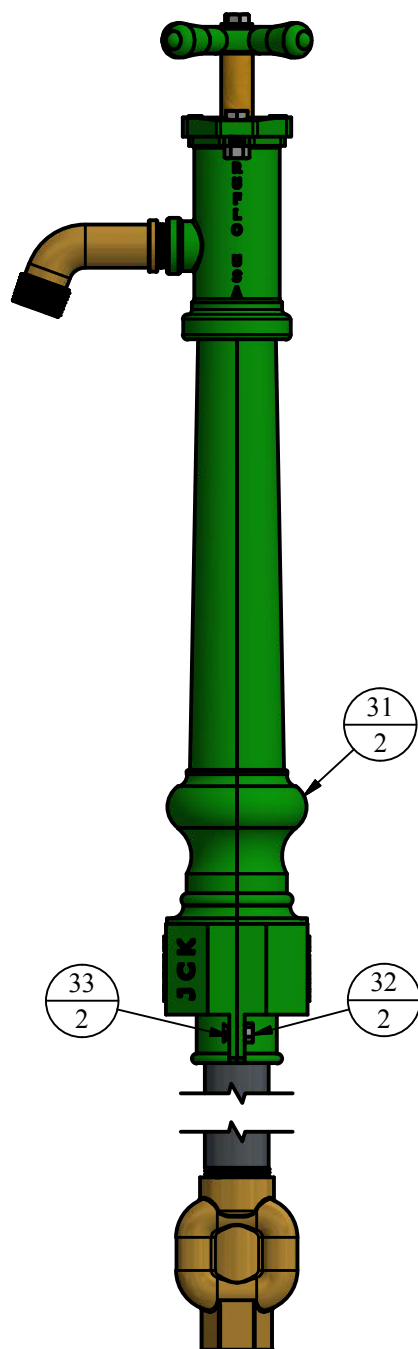

## #TF-100-P PLANT WASHDOWN

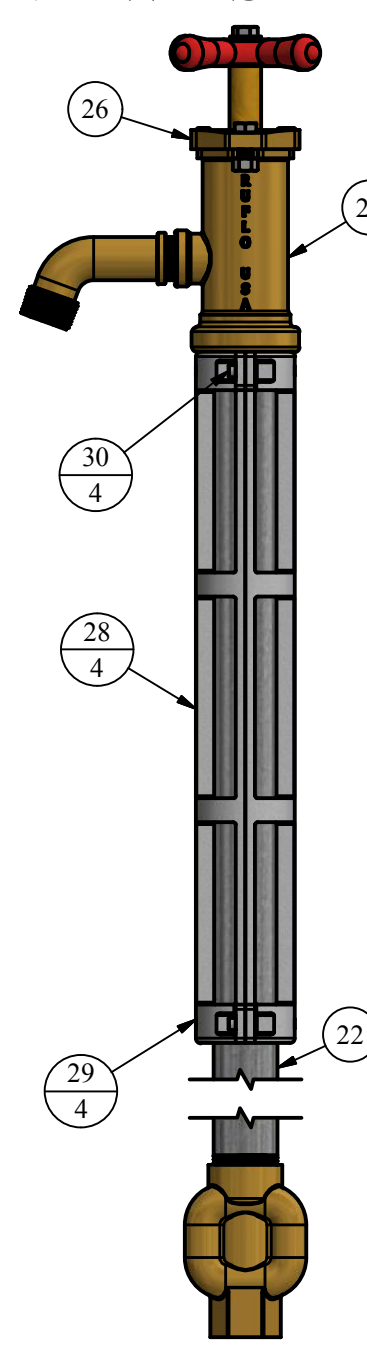

## LEGEND

- (X) → STANDARD TAG
- (X/Y) → TAG WITH Y QUANTITY

NOTE	DESCRIPTION
A	NOT SHOWN
B	PIPE LENGTH DEPENDENT ON DEPTH OF BURY
C	SOLD AS REPLACEMENT PART

**DISCLAIMER:**  
THIS DRAWING IS THE PROPERTY OF THE KUPFERLE FOUNDRY COMPANY. IT IS NOT TO BE USED OR DUPLICATED WITHOUT THE PERMISSION OF THE OWNER.

DRAWN	11/3/2017
SMS CHECKED	
DCL MODIFIED	1/26/2018

SIZE	SCALE
C	1 / 4

DWG NO	#TF-100 Cut Rev_0
--------	-------------------



SHEET	REV
1 OF 1	0